

## Thermo Top

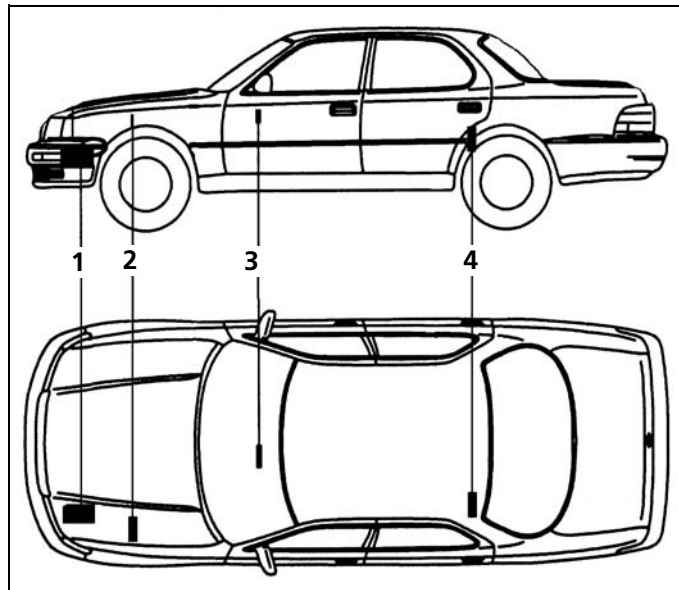

### SAAB 9-5

2.3 / 3.0 Liter - Turbo

Beginning Model Year: 2003

#### Special instructions for this model

Motor vehicle types, motor types and equipment variants, which are not specified in this fitting instruction, were not examined. An installation after this fitting instruction can be however possible.

#### Legend

- 1 BlueHeat Coolant Heater, Exhaust Muffler, and Combustion Air Intake Silencer
- 2 Fuse Holder and Blower Relay
- 3 Timer Control
- 4 Fuel Pump

#### Special Tools

- Hose Clamping pliers
- Torque wrench (1/4" Drive)

## Table of Contents

### Foreword

Parts List	3	Integration into Fuel System	12
Vehicle Information	3	Heater Mounting and Preparation	14
Scope and Purpose	3	Combustion Air Intake and Silencer	16
Symbol Identification	4	Exhaust Routing and Installation	17
General References	5	Integration into Coolant System	18
Preparations	5	Heater Setup	20
Heater Installation Site	5	Concluding Work	21
<b>Installation</b>		Power Connection	21
Electrical - Overview	6	Final Inspection and Start-up	22
German HVAC Harness	7	Heater Lockout Reset Procedure	23
Electrical Harness	8	Heater Plumbing Schematic - Inline Method	24
Blower / Timer Connection	10		



- Improper installation or repair of Webasto heating and cooling systems can cause fire or the leakage of deadly carbon monoxide leading to serious injury or death.
- Installation and repair of Webasto heating and cooling systems requires special factory training, technical information, special tools and special equipment.
- NEVER attempt to install or repair Webasto heating or cooling system unless you have successfully completed the factory training course and have the technical skills, technical information, tools and equipment required to properly complete the necessary procedures.
- ALWAYS carefully follow Webasto installation and repair instructions and heed all WARNINGS.
- Webasto rejects any liability for problems and damage caused by the system being installed by untrained personnel.

## Parts List

Quantity	Part	Part Number
1	Heater Kit	5001102A
1	Installation Kit	5000539B

## Vehicle Information

Manufacturer	Model	Year	Engine Type
SAAB	9-5	Beginning 2003	2.3 / 3.0 Liter - Turbo

## Foreword

This installation requires special expertise from a Webasto training course to install a Webasto Thermo Top heater, which means that it may only be installed by a specially trained workshop or dealership. Webasto cannot accept any liability for faults and damage caused by the system being installed by untrained personnel.

## Scope and Purpose

These non-binding installation instructions are intended to support authorized Webasto trained distributors, dealers and personnel in the installation of the Thermo Top BlueHeat Coolant Heaters.

These non-binding installation instructions apply to the vehicles listed on the front cover of this installation document unless technical modifications on the vehicle influence the installation, excluding all liability claims. Depending on the version and equipment in the vehicle, changes may be required to the installation work set out in these installation instructions. In any event, however, the directives in the "installation manual" and "operating manual" must be followed. Acknowledged engineering conventions must be observed for the installation work.

### ATTENTION

*All relevant state and provincial licensing regulations if any, governing the installation and use of auxiliary heating devices must be observed!*



### CAUTION

*Location of heater, installation of coolant lines, fuel system and components, wiring and control devices are important for proper operation. Failure to comply with the installation instructions provided may result in poor operation or damage to heater and vehicle components.*



### Symbol Identification

Symbols that define sections in manual



Mechanical Preparation



Fuel



Electrical



Exhaust



Coolant



Combustion Air Intake

### General Symbol Descriptions



Warning



Refer to Webasto or Manufacturer Manual



Caution



Attention



Flammable or Combustible

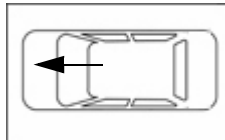

Part Location on Vehicle

**General References**

- Bare body parts, for example around drilled holes, must be treated with anti-corrosive coating.
- Secure hoses, cables and wiring harnesses with cable ties and fit protective hoses around them at chafing points.
- Fit edge protectors (opened fuel hose) to sharp edges.

**Preparation**

**Heater Kit**

- Verify and identify all contents of kit.

**Vehicle**

- Verify fuel content in tank.

**CAUTION**

*For reasons of safety due to the possibility of fuel spillage during the installation of a fuel standpipe, it is recommended there be no more than 3/4 tank or less of fuel present.*

*If fuel quantity is greater than 3/4 of capacity, make provisions to reduce quantity of fuel.*



**Heater Installation Site**

- (1) Webasto Auxiliary Coolant Heater

**ATTENTION**

*The Webasto auxiliary coolant heater is to be installed on the left-hand side of the engine compartment below the battery as shown.*

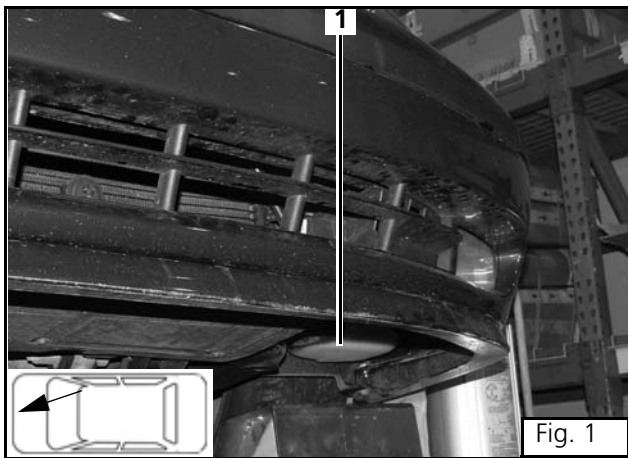

Fig. 1

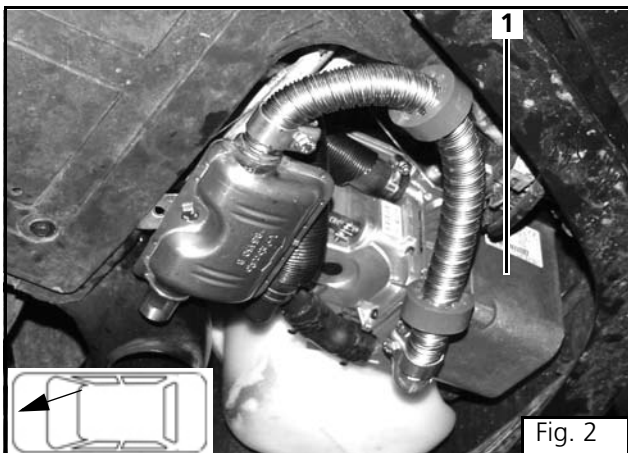

Fig. 2

- (1) Webasto Auxiliary Coolant Heater



### Installation

#### Electrical - Overview

##### ATTENTION

The BlueHeat Coolant Heater for this vehicle will be controlled by the existing heater control module. The Webasto timer control is not necessary



#### Webasto Heater Installed

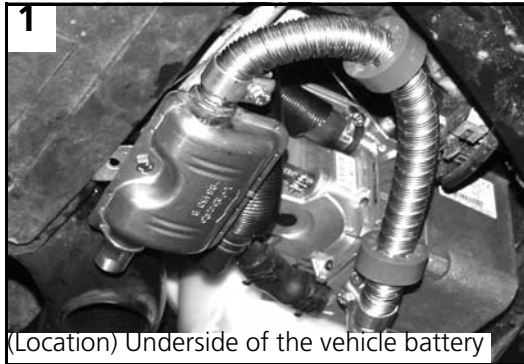

(Location) Underside of the vehicle battery

#### Timer Control Location



(Location) Center of Instrument Panel

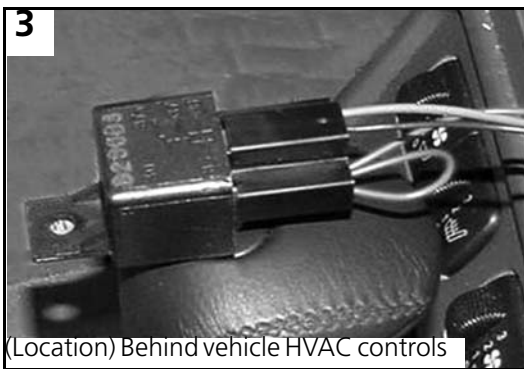
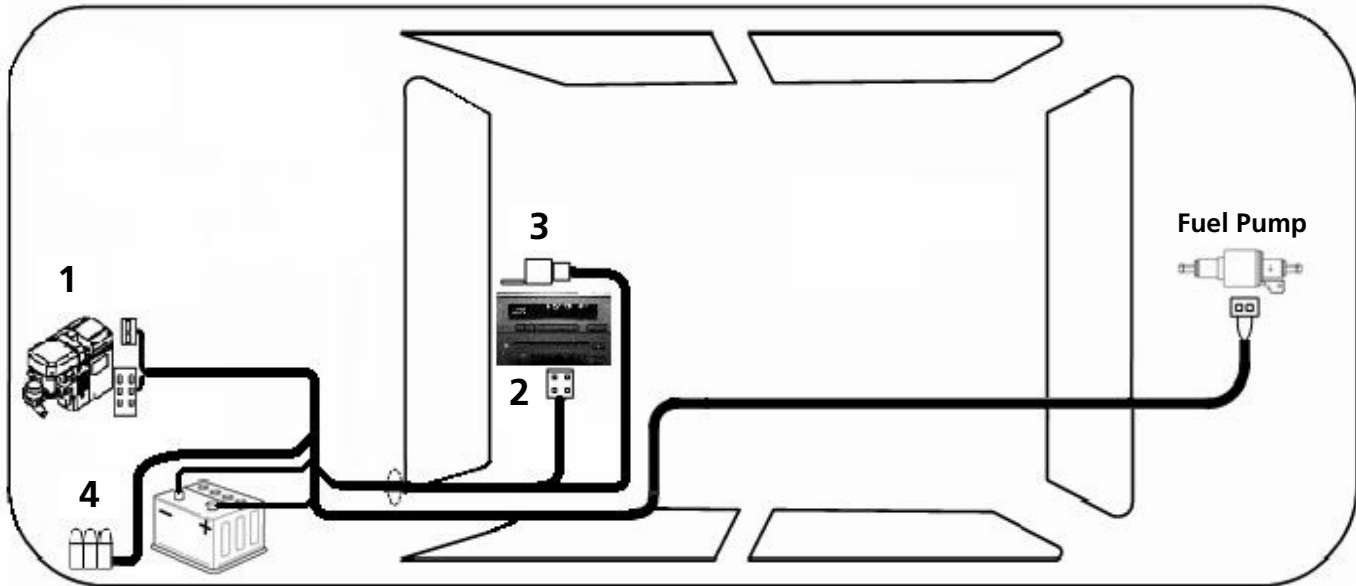

(Location) Behind vehicle HVAC controls

#### Webasto Blower Relay



(Location) Underhood behind fuse panel

#### Webasto Fuse Holder



**German HVAC Harness**

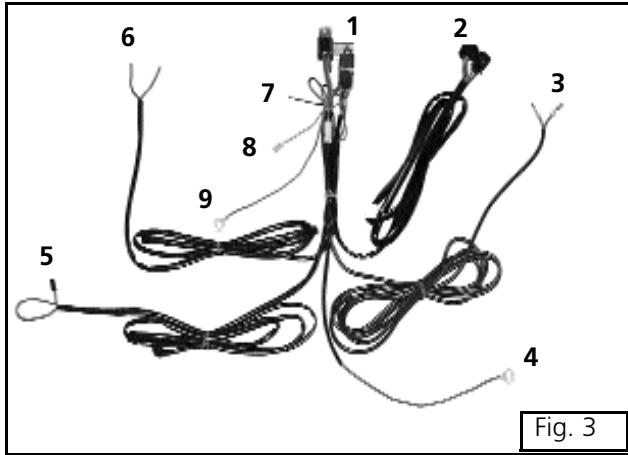

**Legend for Figure 3**

- 1 Fuse Holder and Relay
- 2 To Heater
- 3 To Fuel Metering Pump
- 4 To Power Source
- 5 To Timer and Optional Remote Receiver
- 6 Vehicle HVAC Blower Activation
- 7 Supplemental Heat Activation (Optional)
- 8 To Diagnostic Equipment (Used for Servicing)
- 9 To Ground Source

**ATTENTION**

*Sensitive electronic controls can be damaged if wired incorrectly!*



**ATTENTION**

*Secure HVAC blower control wiring to vehicle structures with nylon wire ties (Image not available)*





### Electrical Harness

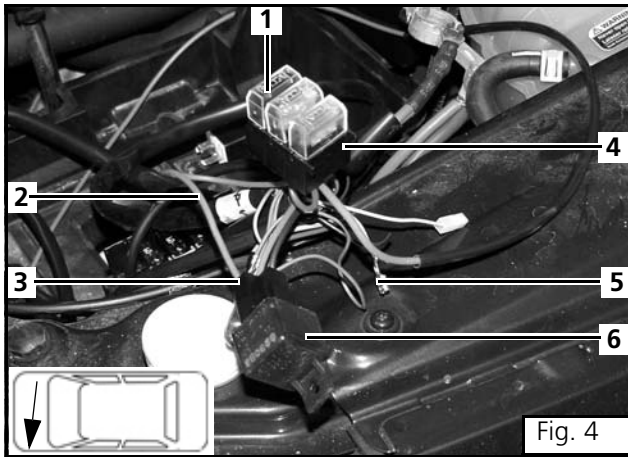

**ATTENTION**

Remove 25 AMP Fuse from fuse Holder. Remove red wire between fuse holder and relay socket and Green/White wire. (Pin 86)

- (1) 25 AMP Fuse
- (2) Red wire between fuse holder and relay socket.
- (3) Relay Socket
- (4) Fuse Holder
- (5) Green/White wire from Relay Socket.
- (6) Relay

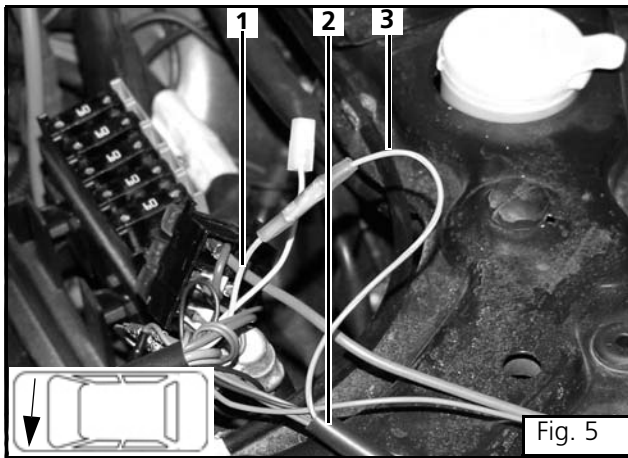

**ATTENTION**

The brown wire located in the timer harness loom can be used to pull the green/white wire through the harness loom. The brown wire is not used in this application.

- (1) Green/White Wire from Relay Socket
- (2) Timer Harness Loom
- (3) Extended Green/ White wire.

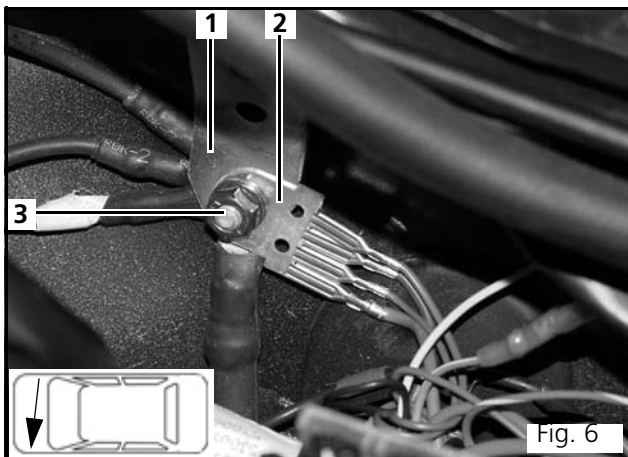

**ATTENTION**

Attach harness ground and fuse holder mounting bracket to existing vehicle ground point as shown.

- (1) Harness Ground Location
- (2) Harness Ground
- (3) Fuse Holder Mounting Bracket Location



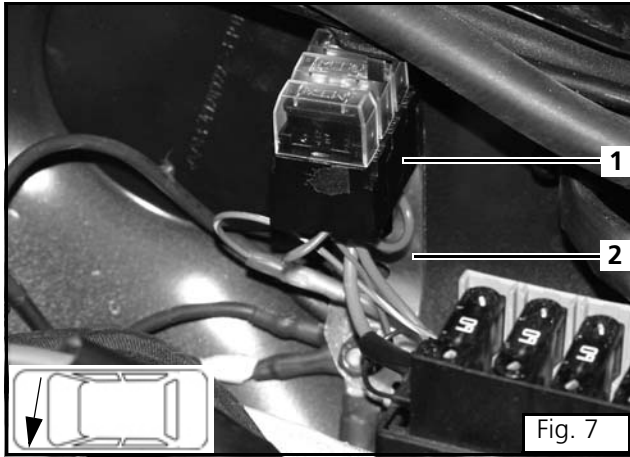

- (1) Fuse Holder
- (2) Fuse Holder Mounting Bracket

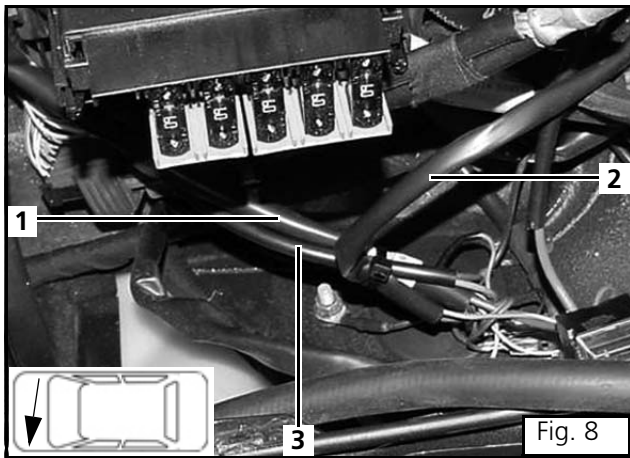

**ATTENTION**

*Route Fuel Pump and Heater Control Harness to Heater mounting location. Route Timer Control Harness towards Vehicle Bulkhead.*

- (1) Fuel Pump Harness
- (2) Timer Harness
- (3) Heater Control Harness

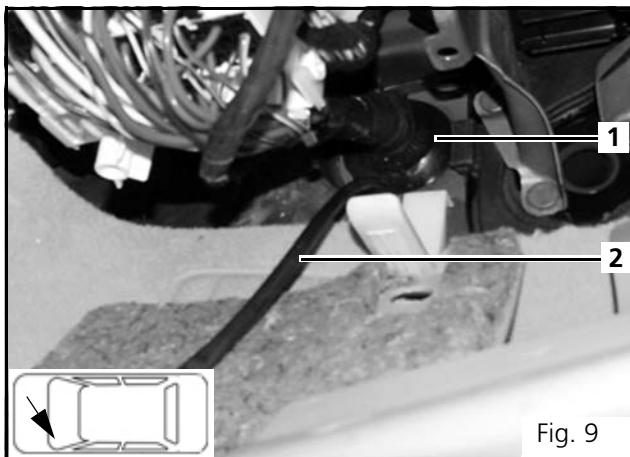

**ATTENTION**

*Cut a 0.5 inch slit in the bulkhead main harness pass-through grommet.*

- (1) Grommet through Bulkhead
- (2) Timer Harness





### Blower / Timer Connection



- (1) Instrument Panel
- (2) HVAC Control Head

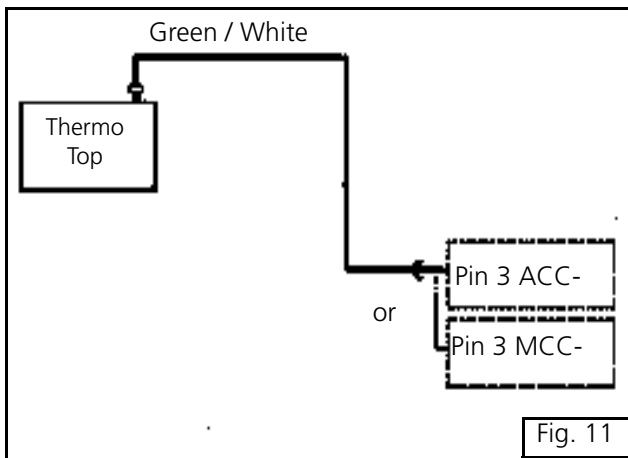

#### ATTENTION

Connect the Green / White wire to pin 3 of the Automatic Climate Control (ACC) or Manual Climate Control (MCC) connector.

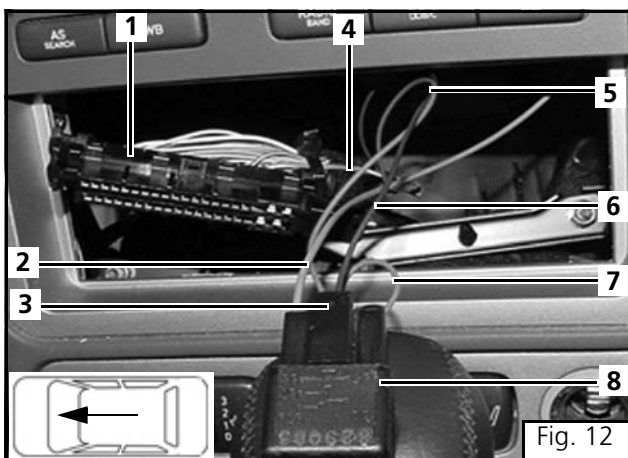

Connect black timer harness wire to relay pin 87.

Connect a red jumper wire between relay pins 30 and 86.

Connect red timer harness wire to relay pin 30.

Using the timer harness purple wire, make a connection from relay pin 85 to pin 18 or 19 of the SID connector. Refer to Fig. 13 for wiring layout.



- (1) ACC or MCC Connector
- (2) Purple Wire from Relay
- (3) Relay Socket
- (4) Green / White Wire
- (5) Red Wire from Relay
- (6) Black Wire from Relay
- (7) Red Jumper Wire
- (8) Heater Relay





### Integration into Fuel System

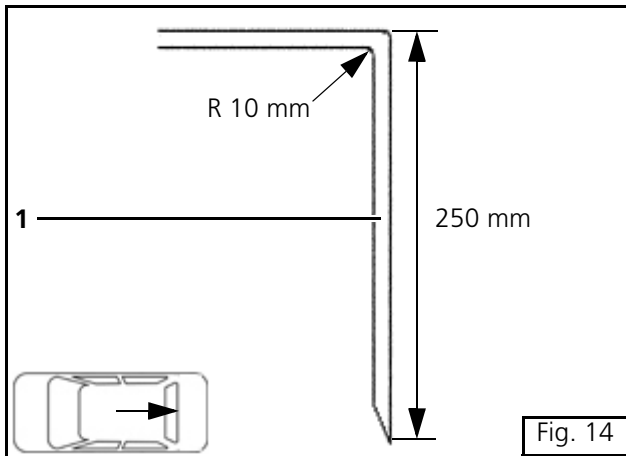

#### ATTENTION

Heat fuel line with a hot air gun and bend it as shown.

Always cut fuel line with a sharp razor knife or razor. DO NOT cut with side cutters, scissors or similar tools as doing so will cause a restriction inside the fuel line.

- (1) Plastic Fuel Line

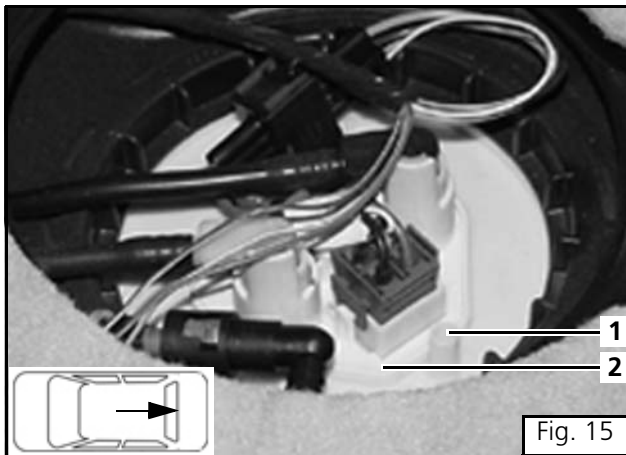

#### CAUTION

When drilling a hole, always keep drill bit straight or damage may result.

#### ATTENTION

Drill out the bottom of the fuel line nipple using a 13/64 in. drill bit. Use a long drill bit with a minimum length of 100 mm (3.93 inches). Use a drill stop. Max free drill length 25 mm (0.98 inch)

- (1) Fuel Line Nipple
- (2) Vehicle Sending Unit

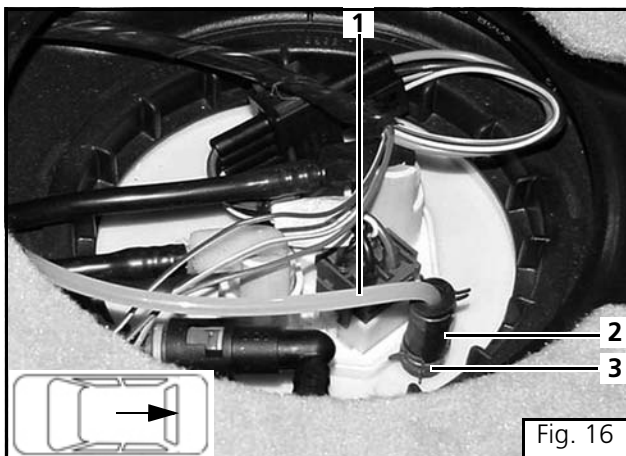

#### ATTENTION

Pre-assemble rubber fuel line connector with two hose clamps. Do not tighten clamps at this time.

Position fuel line approximately 1 inch from the bottom of the fuel tank and tighten clamps.

- (1) Fuel Line
- (2) Fuel Line Connector
- (3) Fuel Line Clamps



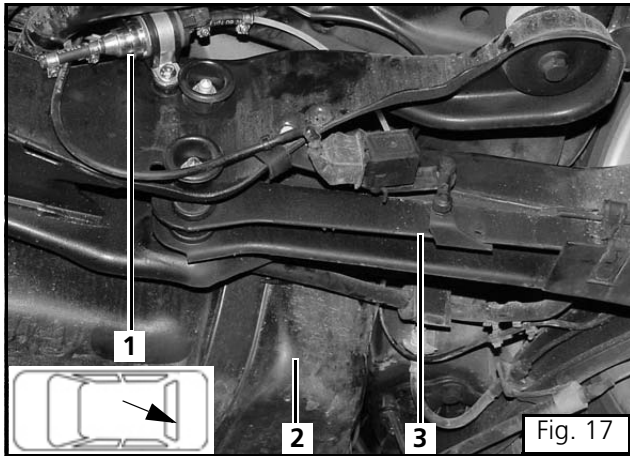

**ATTENTION**

Install heater fuel pump on vehicle crossmember with P-Clamp and provided hardware.

- (1) Fuel Pump
- (2) Vehicle Fuel Tank
- (3) Vehicle Crossmember

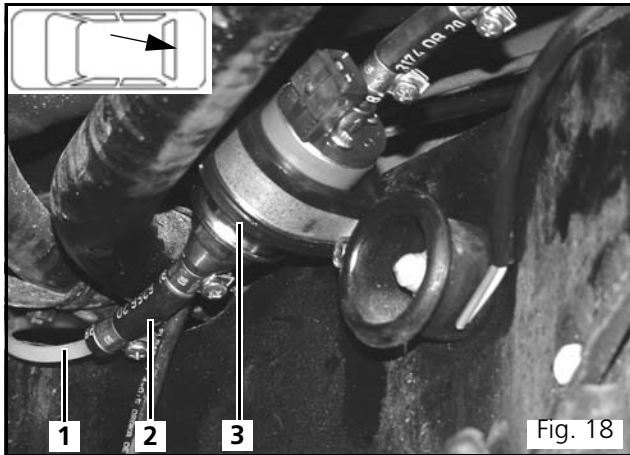

**WARNING / FLAMMABLE**

Ensure fuel line is butted up against fuel pump inlet before securing outboard clamp.

**ATTENTION**

Route fuel line from fuel sender to inlet port of fuel pump.

- (1) Fuel Line
- (2) Fuel Line Connector
- (3) Fuel Pump

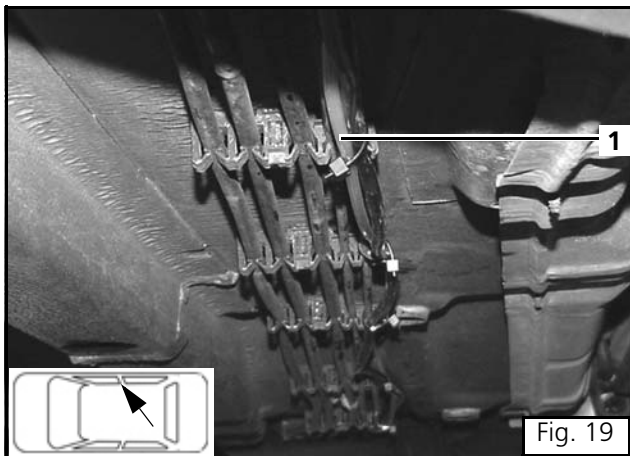

**ATTENTION**

Route fuel line alongside vehicle fuel line harness to heater mounting location.

- (1) Fuel Line Routing to Heater





### Heater Mounting and Preparation

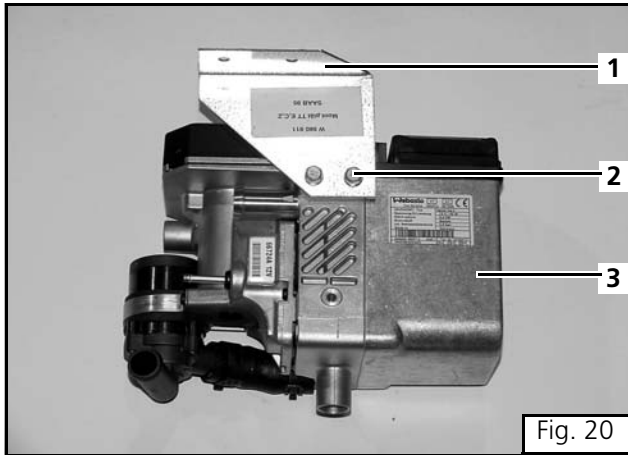

- (1) Large Heater Bracket
- (2) EJOT Screw
- (3) Webasto Heater

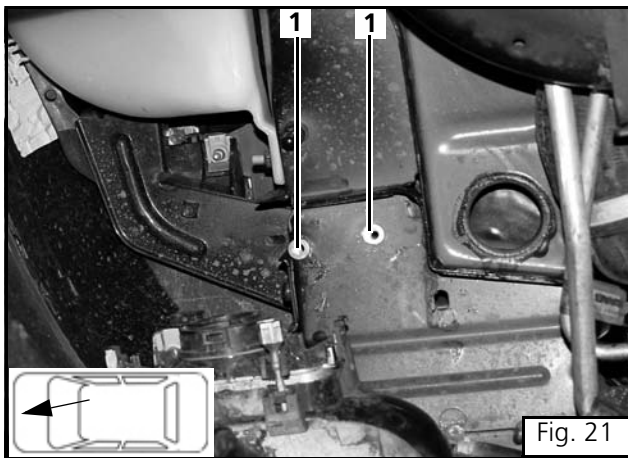

#### ATTENTION

*Using heater mounting bracket as a template, locate, mark, and drill two 13/64 holes in vehicle underbody in location shown.*



- (1) Rivnuts installed into drilled holes as shown

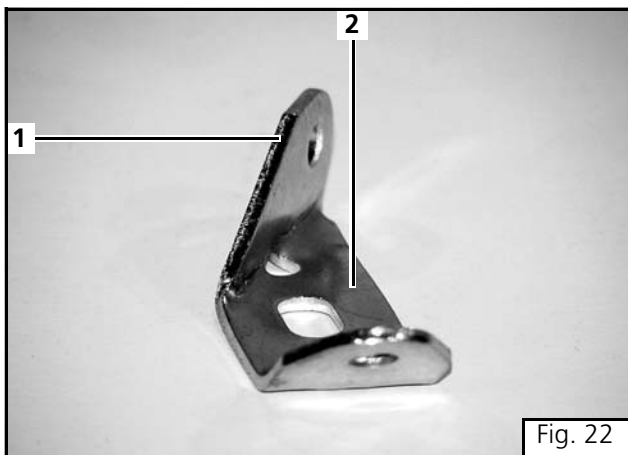

- (1) Bend Small Heater Mounting Bracket as shown.

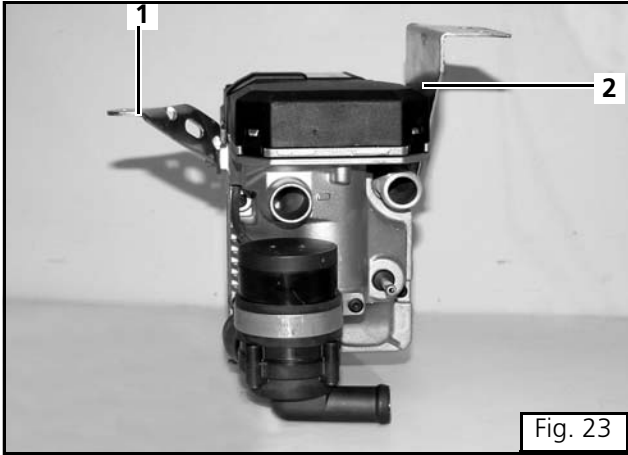

- (1) Small Mounting Bracket attached to Heater
- (2) Large Mounting Bracket attached to Heater

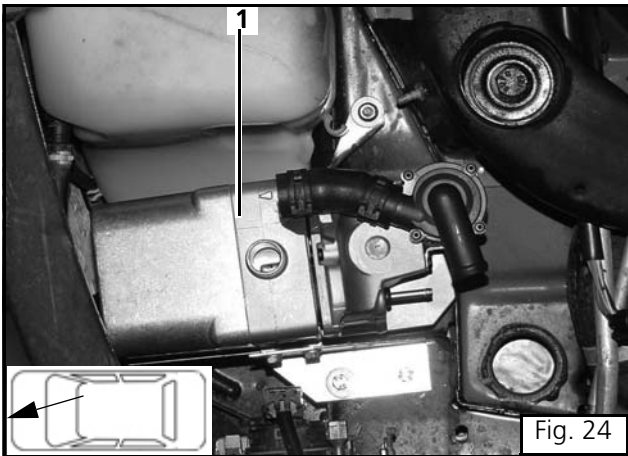

**ATTENTION**

Mount heater to vehicle underbody with hardware provided as shown. Connect power and control harness connectors into heater receptacle sockets.



- (1) Heater Mounted to Vehicle Underbody

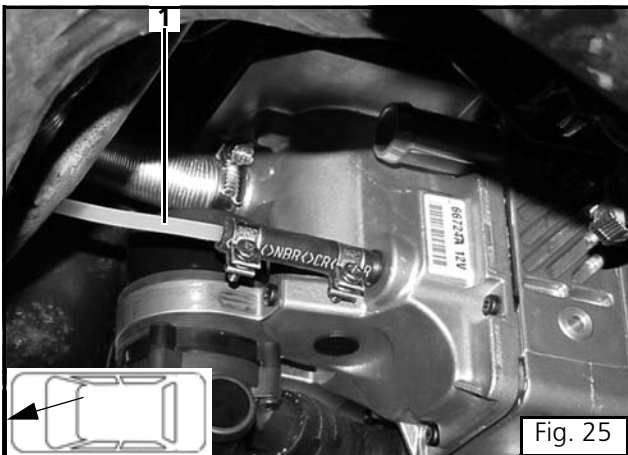

- (1) Fuel Line from Fuel Pump output



### Combustion Air Intake and Silencer

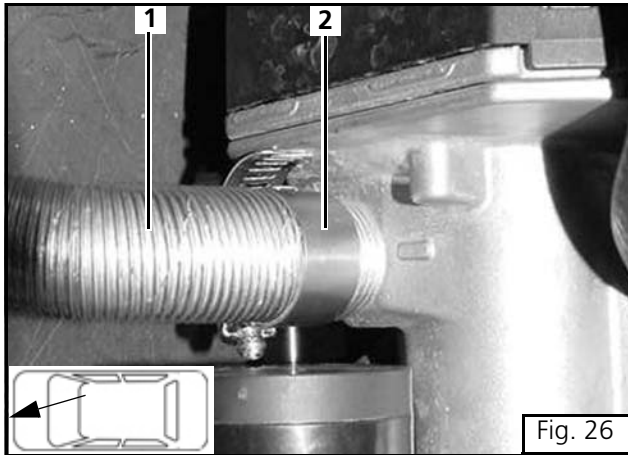

- (1) Combustion Air Intake Tube
- (2) Intake Tube Hose Clamp

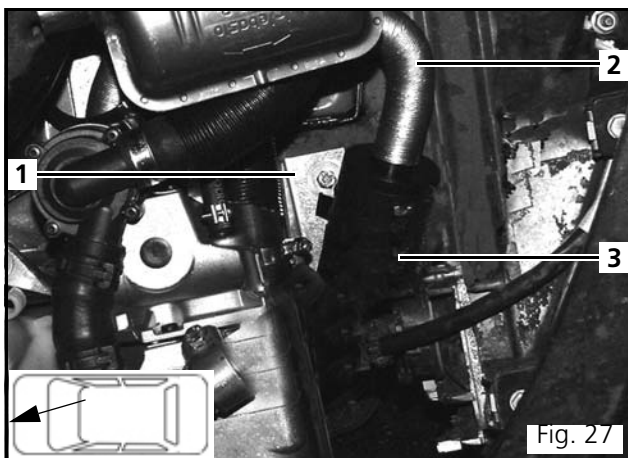

- (1) Webasto Heater Installed
- (2) Combustion Air Intake Tube
- (3) Air Intake Silencer



## Exhaust Routing and Installation

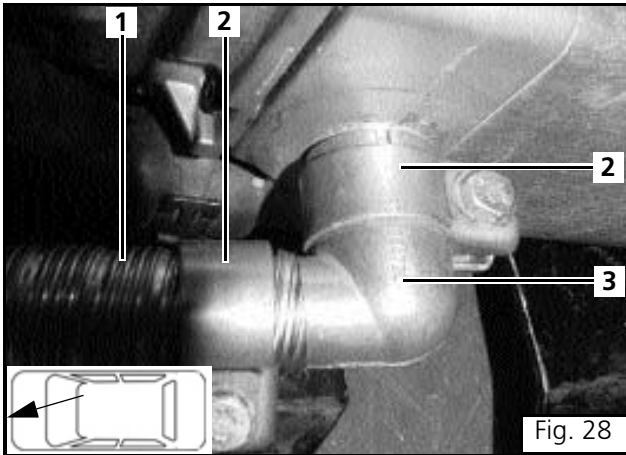

- (1) Exhaust Pipe
- (2) Securing Clamp
- (3) 90 Degree Exhaust Fitting

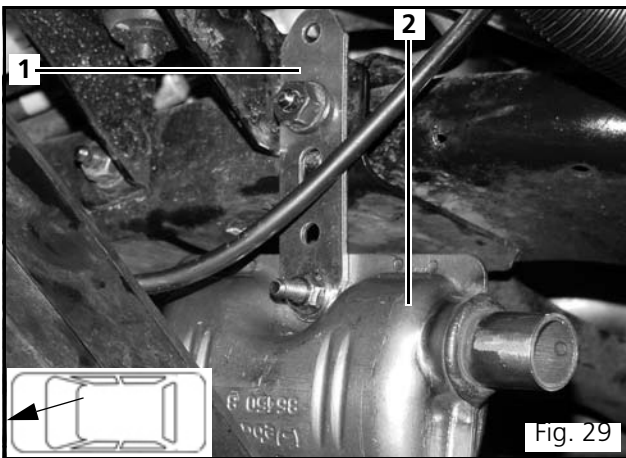

- (1) Perforated Muffler Strap
- (2) Exhaust Muffler

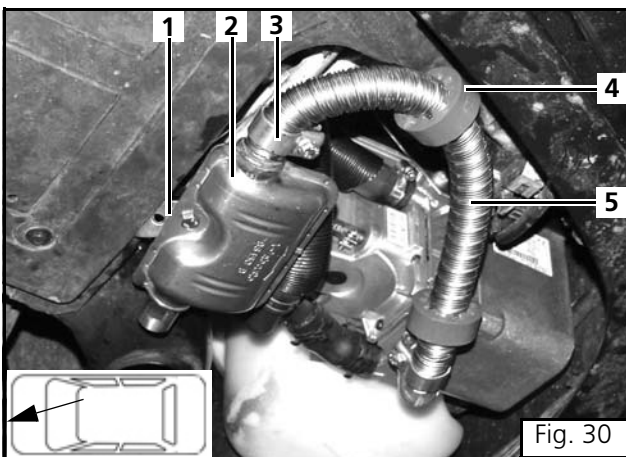

**ATTENTION**

*Ensure the heat insulators are properly positioned and that the tail pipe is positioned downward.*

- (1) Perforated Muffler Strap
- (2) Exhaust Muffler
- (3) Securing Clamp
- (4) Heat Insulators
- (5) Exhaust Pipe





### Integration into Coolant System

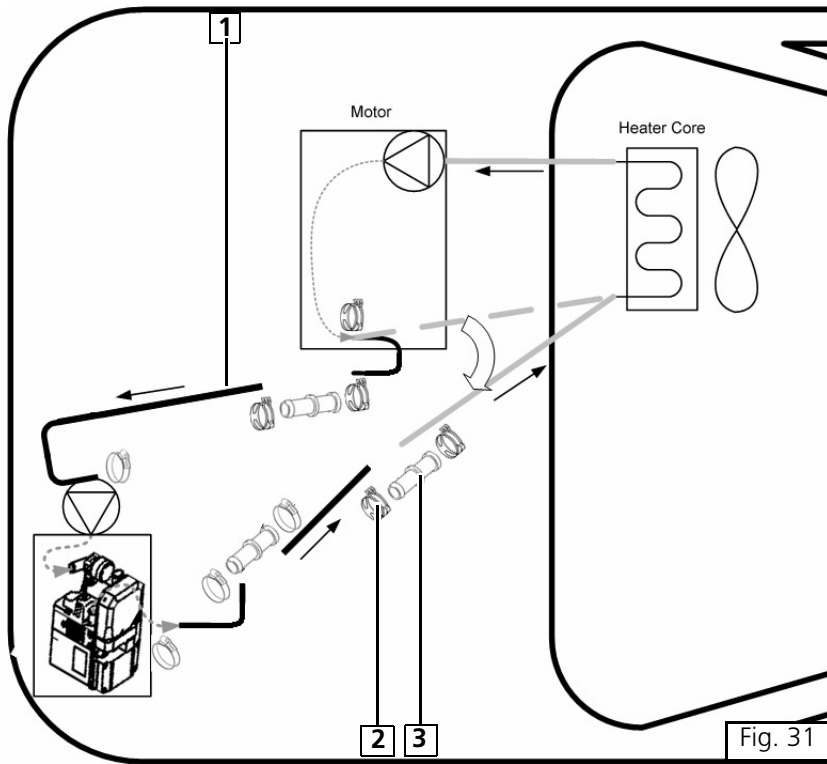

**ATTENTION**

*Fig. 32 displays the integration of the Webasto Coolant Heater into the vehicles cooling system.*

**ATTENTION**

*Torque all hose clamps to 2.0 - 2.5 Nm (18 - 22 lb.-in.).*

- (1) Webasto Coolant Hose
- (2) Hose Clamp
- (3) Hose Connector

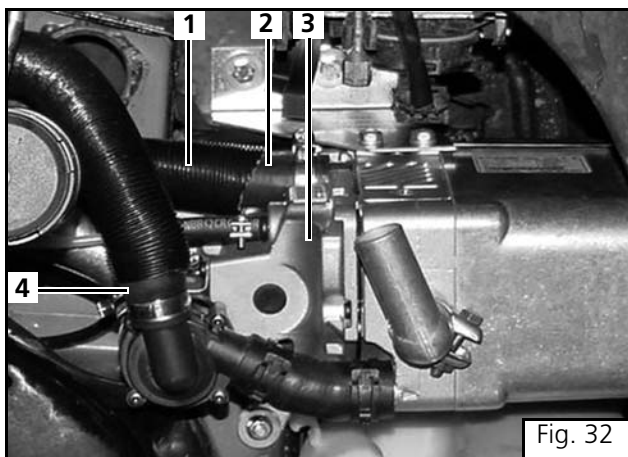

**ATTENTION**

*Using the supplied coolant hose, route inlet and outlet hoses from the heater up to the underhood engine compartment. Refer to Fig. 32 for connecting to the vehicle cooling system.*

- (1) Protective Loom
- (2) Coolant Outlet Hose
- (3) Webasto Heater
- (4) Coolant Inlet Hose



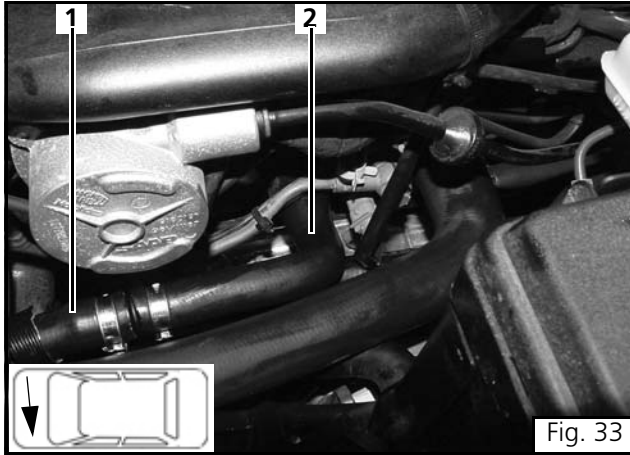

**ATTENTION**

*Loosen constant pressure hose clamp at engine head and rotate coolant supply hose toward front of engine. Connect vehicle coolant supply hose to Webasto heater inlet hose.*

- (1) Webasto Inlet Hose
- (2) Vehicle Coolant Supply Hose

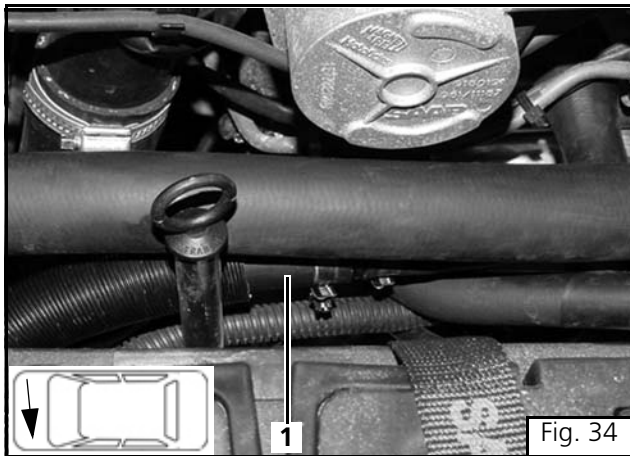

**ATTENTION**

*Connect heater core inlet hose to Webasto heater outlet hose.*

*Secure coolant lines to available components with nylon wire ties. Keep lines away from hot exhaust and turbo components.*

- (1) Vehicle Heater Core Outlet Hose

**NOTE:**

*Also see the plumbing schematic in the back of this manual for a general outline of the coolant circuit arrangement.*





### Heater Setup



#### ATTENTION

The vehicle battery must be reconnected before performing the following steps.

Using the Tech 2, program the SID module to acknowledge the presence of the Webasto heater.

With ignition in the OFF position, press the clear button to activate the webasto heater timer setup. The HVAC Control screen will display "HEATER OFF."

- (1) Clear Button for HVAC Control



#### ATTENTION

Press the set button to initiate the timer sequence.

Press the minus (-) button for "Instant On / Instant Off." This will immediately turn the heater On or Off.

- (1) Set Button for HVAC Control
- (2) Minus (-) Button for HVAC Control



#### ATTENTION

Press the plus (+) button (4) to program heater start-up times.

- (1) Plus Button (+) for HVAC Control





### Concluding Work

- Install all vehicle parts, panels and components removed during heater installation.
- Check that all hose lines, hose clamps, pipe clips and electrical connections are secure.
- Secure all loose lines and cables with nylon cable ties.
- Spray the heater components and electrical connections with an anti-corrosive wax coating.

### Power Connection

#### ATTENTION

*Connect red power lead to existing power stud in front of fuse panel as shown. Reconnect battery ground cable(s).*

- (1) Auxiliary Power Stud
- (2) Webasto Power Lead
- (2) Fuse Panel Power Stud

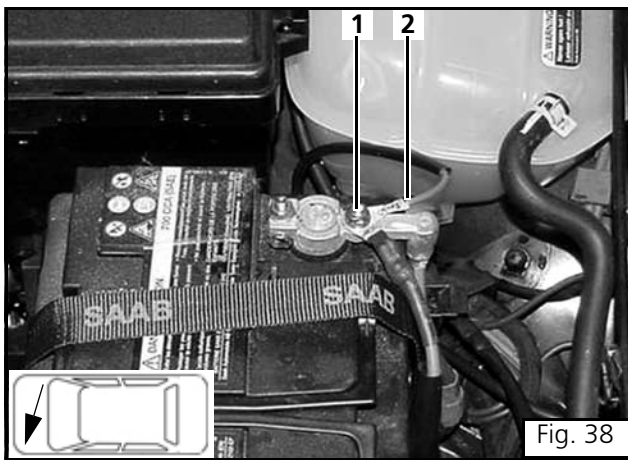

Fig. 38



## Final Inspection and Initial Start-up

### Final Inspection

Inspect installation for:

- Loose fasteners.
- Exhaust system routing and clamp tightness.
- Combustion air intake tube routing and clamp tightness.
- Loose coolant line clamps.
- Pinched coolant lines.
- Routing of coolant lines and coolant lines securely tied and protected against chaffing and related damage.
- Loose fuel line clamps.
- Routing of fuel lines and fuel lines securely tied and protected against chaffing and related damage.
- Loose wiring connections and battery connections.
- routing of wiring harness and wiring harness securely tied and protected against chaffing and related damage.
- Check operation of vehicle heater fan with Webasto heater OFF.

### Initial Start-up

1. Top off cooling system with coolant per engine/vehicle manufacturers recommendations.
2. Set interior heater control to maximum heat position (hot) and switch off air conditioning system.
3. Start the vehicle engine and run on fast idle for 5 minutes to purge any remaining air from the Webasto heater and coolant system. While the engine is running check:
  - Hose connections for leaks.
  - Coolant level in expansion tank. (Add coolant as needed)
4. Switch off the engine.

### ATTENTION

*More than one start-up attempt of the heater may be required to purge air from fuel system before heater will start. Cycle heater Off and On after each failed start attempt until heater starts successfully. After 3 consecutive unsuccessful start attempts, the webasto control unit enters into Heater lockout. See Heater Lockout section for reset instructions.*



5. Switch on the Webasto heater by means of the instant heat button on timer and check:
  - Timer panel and instant heat indicator illuminates.
  - Circulating pump in operation.
  - Initiation of start-up sequence.
  - Successful start-up and operation.
6. Allow heater to run for 20 minutes or until coolant is heated to temperature. Re-tighten all hose clamps.

### ATTENTION

*Engine coolant temperature gauge may read lower than actual Webasto heater output temperature. This is due to the location of the temperature gauge sensor on engine.*





### Heater Lockout Reset Procedure

The BlueHeat is designed with a lockout safety feature built into the control unit. After 3 consecutive unsuccessful startup attempts, the heater will lock itself out from any further start attempts. The heater may also enter the lockout mode after experiencing an overheat condition.

Reset Heater "Lockout" mode by performing the following procedure:

1. Ensure timer or switch is in the "OFF" position. Turn timer or switch to the "On" position. Remove main fuse F2 (20 Amp), reinsert after 5 seconds.
2. Cycle timer or switch off and then back on once more. Remove fuse F2 once again and reinsert after 5 seconds. Heater should attempt to start after inserting fuse.

### ATTENTION

- Coolant temperature must be below the lower threshold before heater will attempt to start.
- The engine coolant must reach 86 °F (30 °C) before the Webasto heater will attempt to start vehicles blower fan.
- Should the heater fail to start or operate correctly, call your Webasto technical representative at:  
**1-800-555-4518**





Heater Plumbing Schematic - Inline Method

WEBASTO THERMO TOP C INLINE COOLANT SCHEMATIC

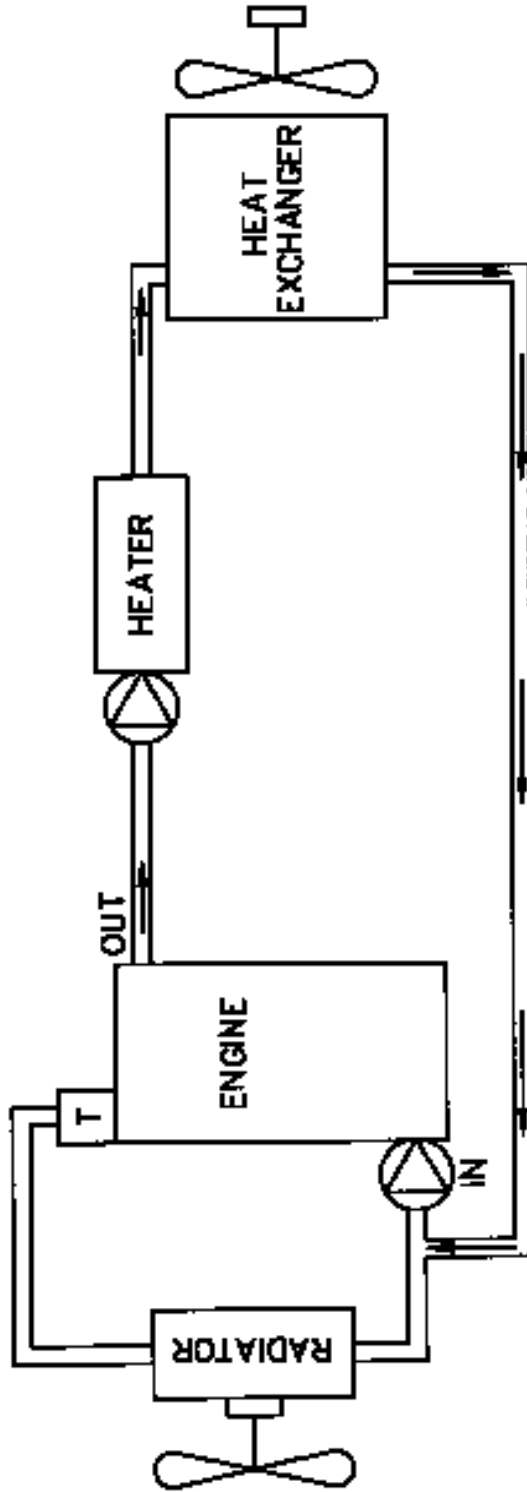

 = THERMOSTAT

 = COOLANT PUMP (2 PLC'S)

**NOTES:**



**Webasto Product N.A., Inc.**

Technical Assistance Hotline

USA: (800) 555-4518

Canada: (800) 667-8900